

NOTES: Unless otherwise specified.

1. Machined surfaces \perp .001 in 12" \parallel .002 in 12" \square .001 in 12"
2. Deburr and break all sharp edges.

THE INFORMATION CONTAINED IN THIS DRAWING IS THE SOLE PROPERTY OF ABBOTT WORKHOLDING PRODUCTS. ANY REPRODUCTION IN PART OR WHOLE WITHOUT THE WRITTEN PERMISSION OF ABBOTT WORKHOLDING PRODUCTS IS PROHIBITED.

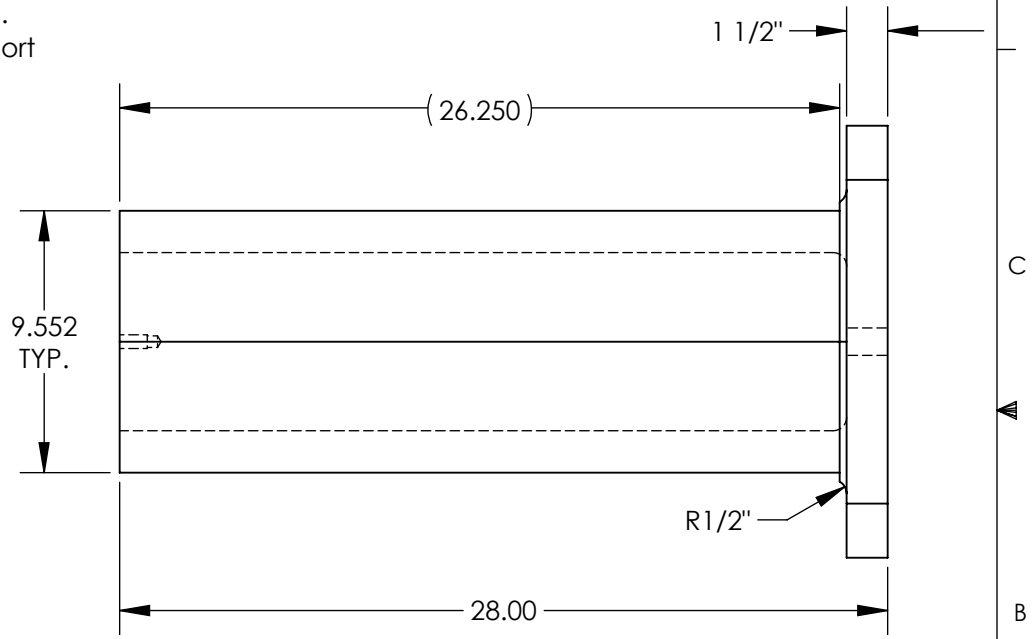
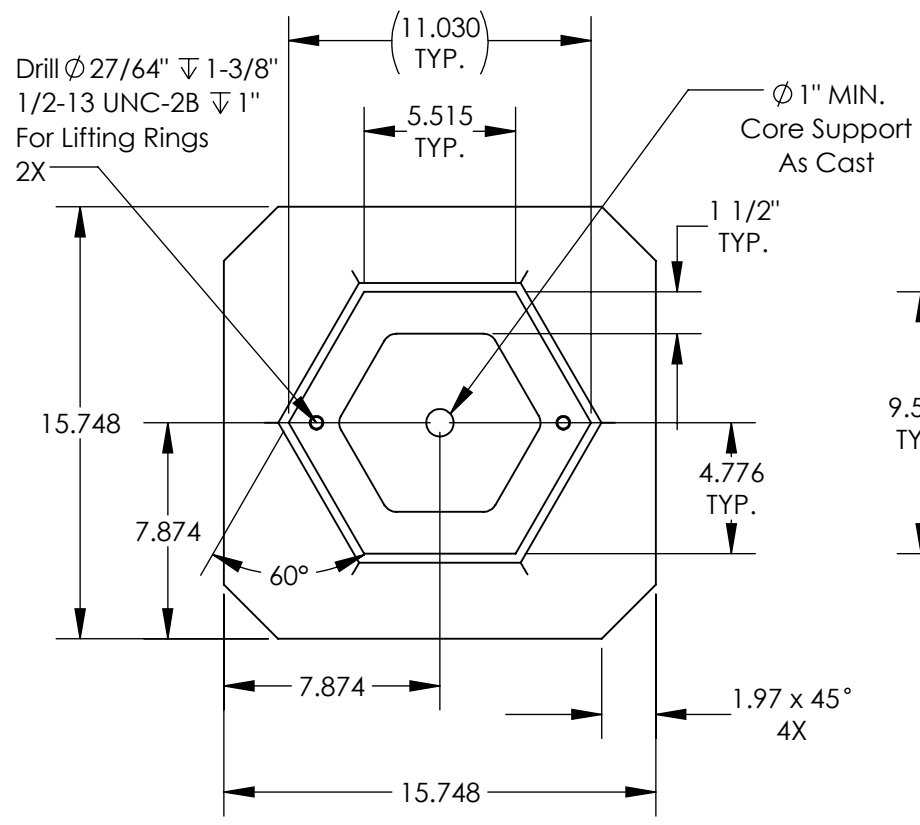

UNLESS OTHERWISE SPECIFIED DIMENSIONS ARE IN INCHES TOLERANCES ARE: FRACTIONS DECIMALS ANGLES $\pm 1/32$.XX \pm .015 $\pm 5^\circ$.XXX \pm .005 .XXXX \pm .0005	
DRAWN ZGG	DATE 08/12/24
MATERIAL 713	WEIGHT(POUNDS) 152.2
STYLE TC	DISPOSITION Released

Abbott Workholding Products
 430 McCall Road
 Manhattan, KS 66502
 785-776-8555
 785-587-0004 Fax
 800-528-6459
 www.abbottworkholding.com
 engineering@abbottworkholding.com

CUSTOMER: Stock	SIZE A	Part Name H52810-400BS	REV. --
--------------------	-----------	---------------------------	------------