

THE INFORMATION CONTAINED IN THIS DRAWING IS THE SOLE PROPERTY OF ABBOTT WORKHOLDING PRODUCTS. ANY REPRODUCTION IN PART OR WHOLE WITHOUT THE WRITTEN PERMISSION OF ABBOTT WORKHOLDING PRODUCTS IS PROHIBITED.

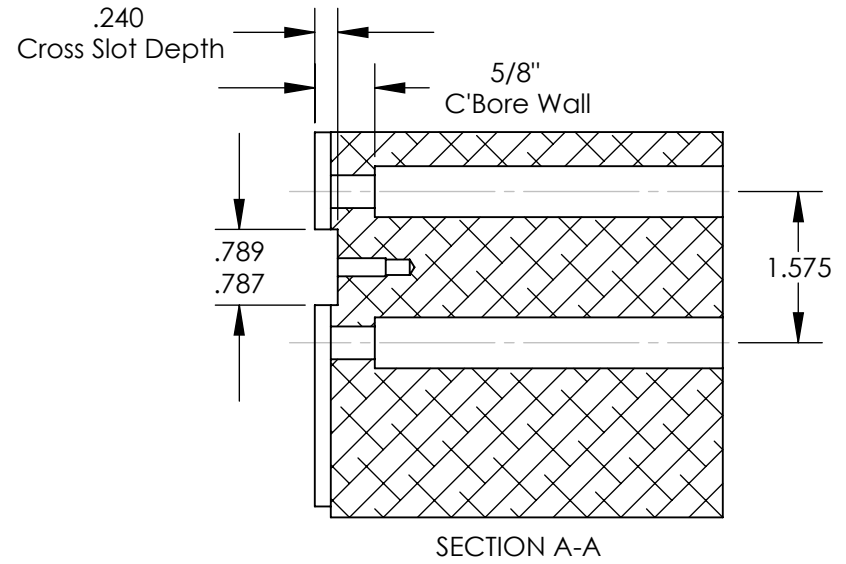
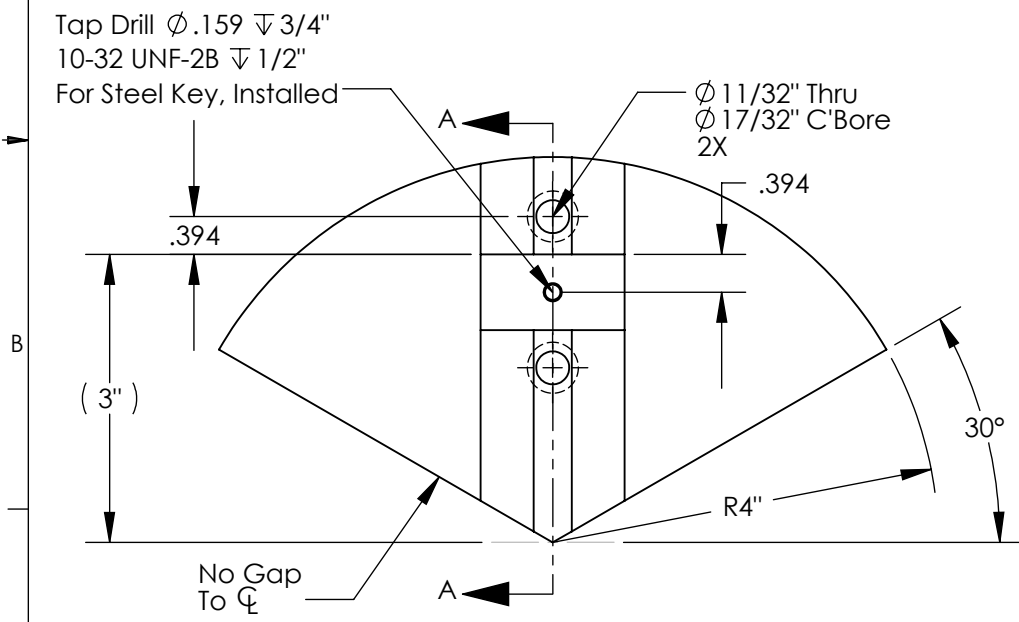
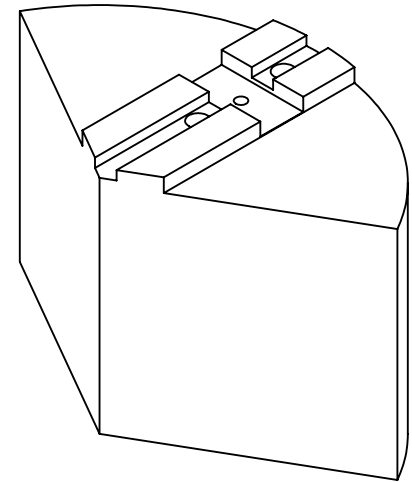
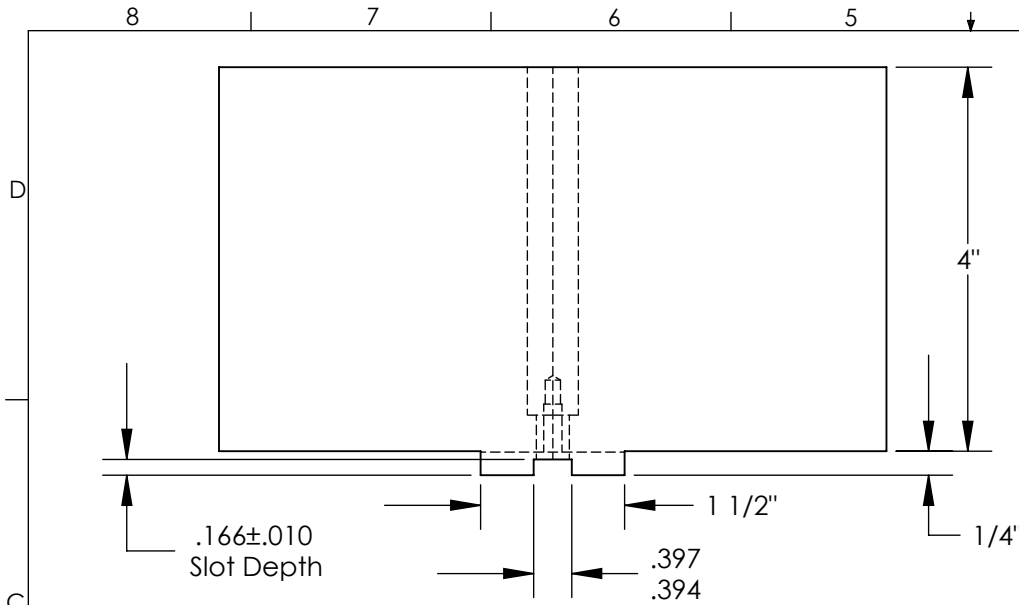

UNLESS OTHERWISE SPECIFIED DIMENSIONS ARE IN INCHES TOLERANCES ARE: FRACTIONS DECIMALS ANGLES $\pm 1/32$ .XX $\pm .015$ $\pm 5^\circ$ .XXX $\pm .005$ .XXXX $\pm .0005$		<b>Abbott Workholding Products</b> 430 McCall Road Manhattan, KS 66502 785-776-8555 785-587-0004 Fax 800-528-6459 www.abbottworkholding.com engineering@abbottworkholding.com	
DRAWN ZGG	DATE 05/06/16	CUSTOMER: Stock	
MATERIAL 6061	WEIGHT(POUNDS) 6.6	SIZE A	Part Name MTG8MDP1
STYLE D	DISPOSITION Released	CUSTOMER: Stock	REV. B