

8 7 6 5 4 3 2 1

THE INFORMATION CONTAINED IN THIS DRAWING IS THE SOLE PROPERTY OF ABBOTT WORKHOLDING PRODUCTS. ANY REPRODUCTION IN PART OR WHOLE WITHOUT THE WRITTEN PERMISSION OF ABBOTT WORKHOLDING PRODUCTS IS PROHIBITED.

NOTES: Unless otherwise specified.

- 1. Machined surfaces \perp .001 in 12" \parallel .002 in 12" \square .001 in 12"
- 2. Deburr and break all sharp edges.

Includes T88TP Top Plate And (2) Lifting Rings Installed

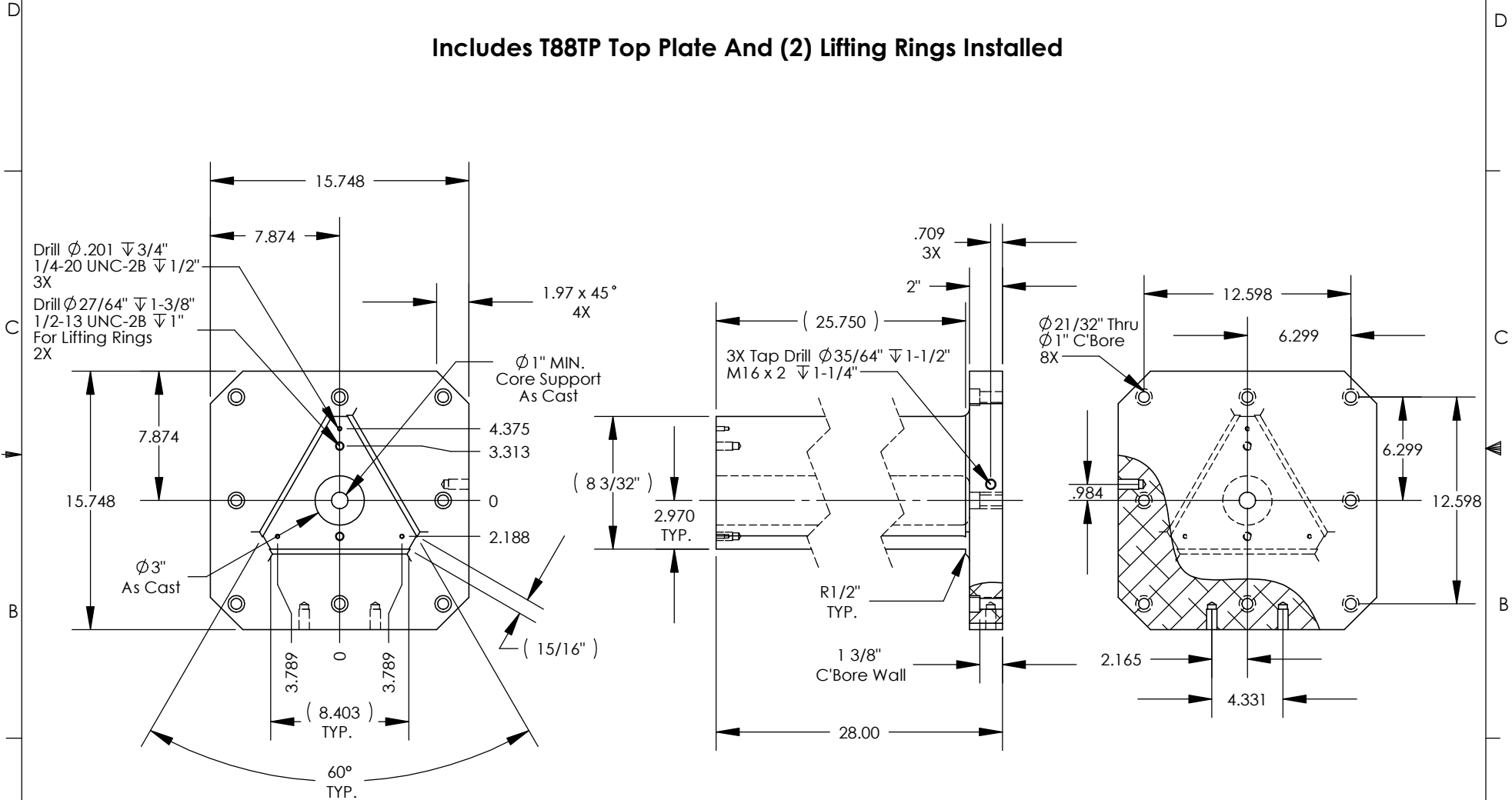

UNLESS OTHERWISE SPECIFIED DIMENSIONS ARE IN INCHES	
TOLERANCES ARE:	
FRACTIONS	DECIMALS ANGLES
$\pm 1/32$.XX \pm .015 \pm 5°
	.XXX \pm .005
	.XXXX \pm .0005
DRAWN	DATE
ZGG	02/11/19
MATERIAL	WEIGHT(POUNDS)
713	148
STYLE	DISPOSITION
TC	Released

Abbott Workholding Products

430 McCall Road
 Manhattan, KS 66502
 785-776-8555
 785-587-0004 Fax
 800-528-6459

www.abbottworkholding.com
 engineering@abbottworkholding.com

CUSTOMER:	Part Name	REV.
Stock	A T8288-400JIS	--

8 7 6 5 4 3 2 1