

THE INFORMATION CONTAINED IN THIS DRAWING IS THE SOLE PROPERTY OF ABBOTT WORKHOLDING PRODUCTS. ANY REPRODUCTION IN PART OR WHOLE WITHOUT THE WRITTEN PERMISSION OF ABBOTT WORKHOLDING PRODUCTS IS PROHIBITED.

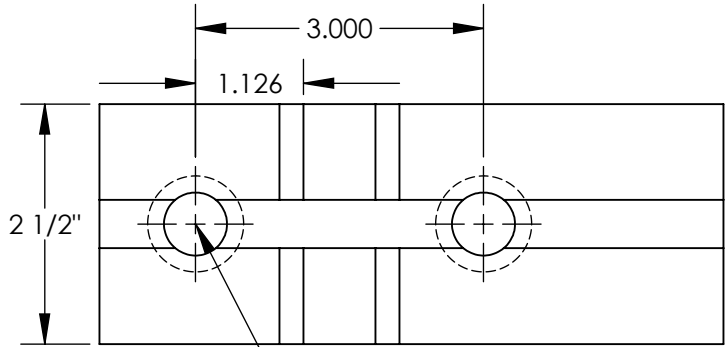

Ø 21/32" Thru
Ø 1" C'Bore
2X

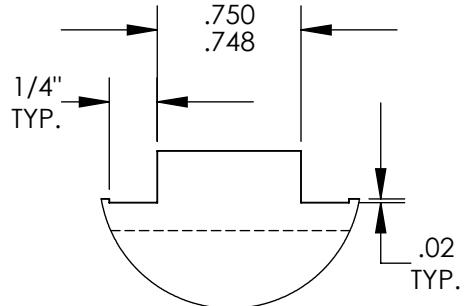

DETAIL B
SCALE 1 : 1

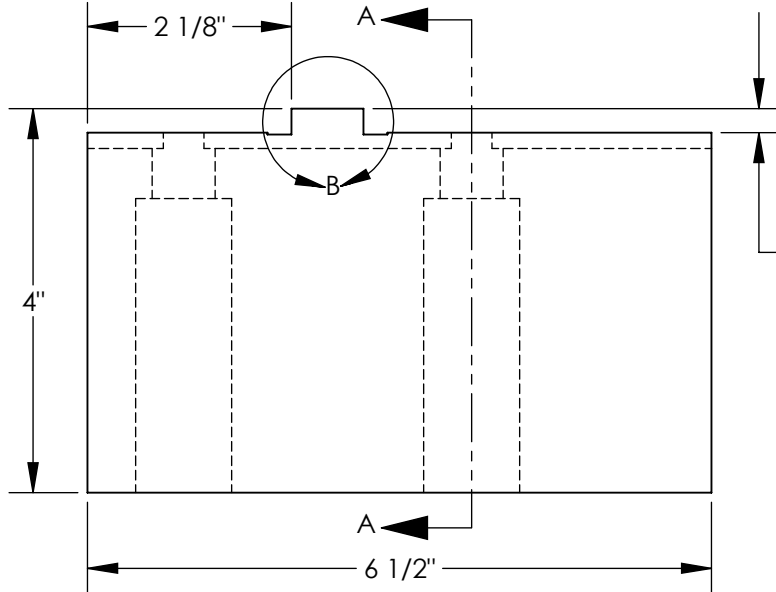
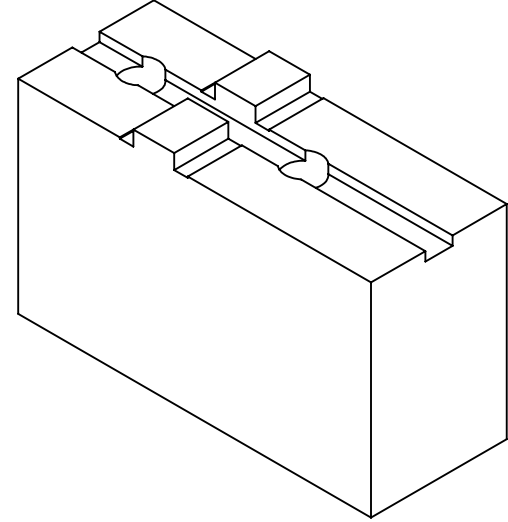

.250±.010
Tongue Height

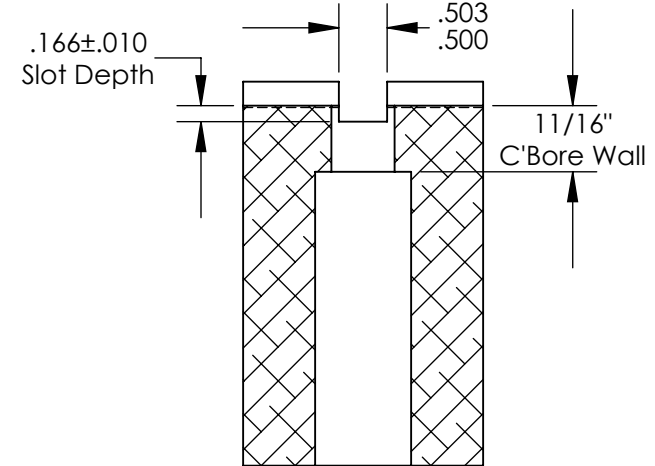

SECTION A-A

UNLESS OTHERWISE SPECIFIED DIMENSIONS ARE IN INCHES TOLERANCES ARE: FRACTIONS DECIMALS ANGLES ± 1/32 .XX ± .015 ± 5° .XXX ± .005 .XXXX ± .0005	
DRAWN ZGG	DATE 10/19/20
MATERIAL 6061	WEIGHT (POUNDS) 5.5
STYLE A	DISPOSITION Released

Abbott Workholding Products

430 McCall Road
Manhattan, KS 66502
785-776-8555
785-587-0004 Fax
800-528-6459

www.abbottworkholding.com
engineering@abbottworkholding.com

CUSTOMER: Stock	SIZE A	Part Name TG15MDA1SQ	REV. B
--------------------	-----------	-------------------------	-----------