

THE INFORMATION CONTAINED IN THIS DRAWING IS THE SOLE PROPERTY OF ABBOTT WORKHOLDING PRODUCTS. ANY REPRODUCTION IN PART OR WHOLE WITHOUT THE WRITTEN PERMISSION OF ABBOTT WORKHOLDING PRODUCTS IS PROHIBITED.

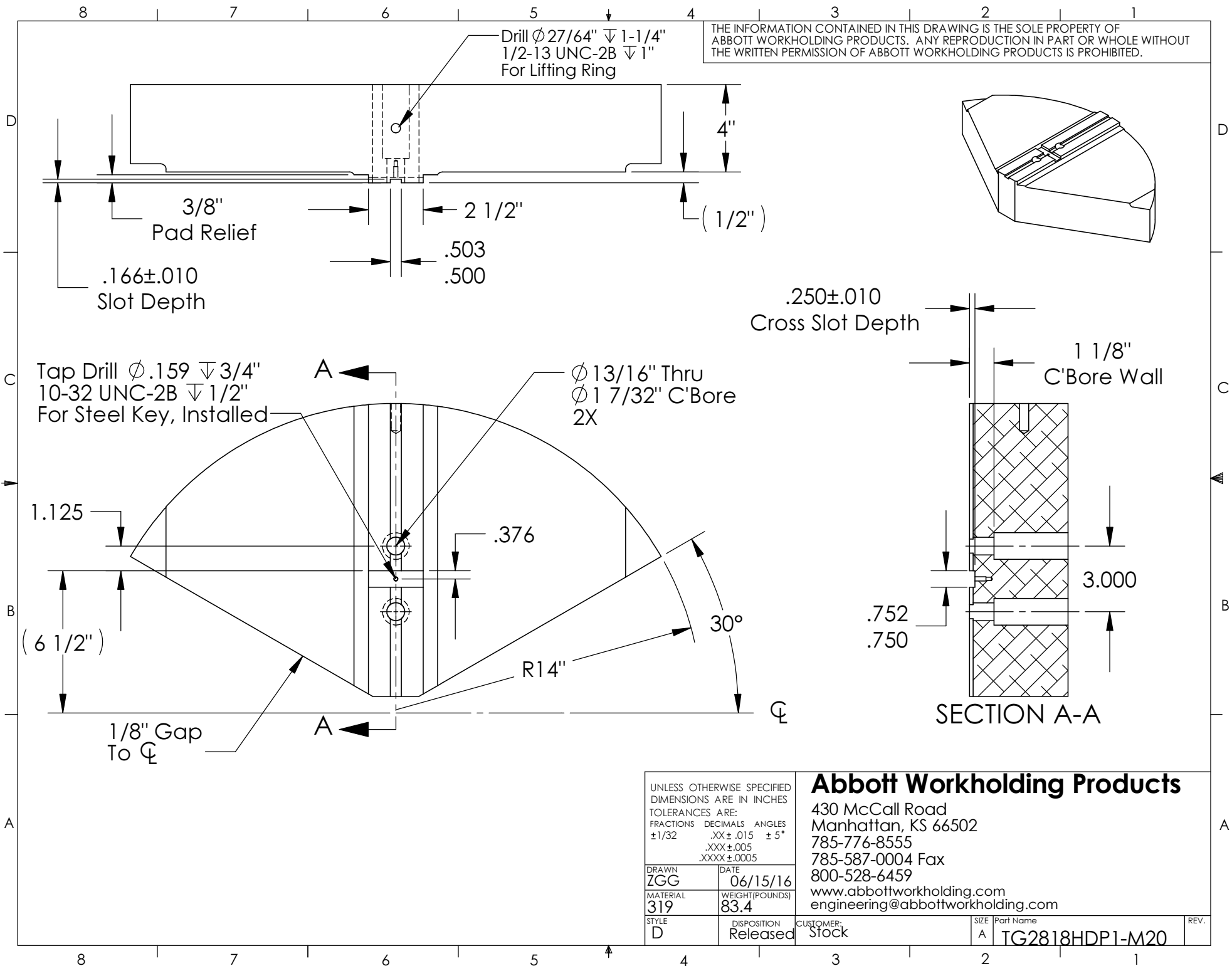

UNLESS OTHERWISE SPECIFIED
 DIMENSIONS ARE IN INCHES
 TOLERANCES ARE:
 FRACTIONS DECIMALS ANGLES
 $\pm 1/32$.XX±.015 $\pm 5^\circ$
 .XXX±.005
 .XXXX±.0005

DRAWN ZGG	DATE 06/15/16
MATERIAL 319	WEIGHT(POUNDS) 83.4
STYLE D	DISPOSITION Released

Abbott Workholding Products

430 McCall Road
 Manhattan, KS 66502
 785-776-8555
 785-587-0004 Fax
 800-528-6459

www.abbottworkholding.com
 engineering@abbottworkholding.com

CUSTOMER: Stock	SIZE A	Part Name TG2818HDP1-M20	REV.
--------------------	-----------	-----------------------------	------